

KORG

PORTABLE ORGAN

CX-3

Service Manual

CONTENTS

1. SPECIFICATIONS	2
2. STRUCTURAL DIAGRAM	3
3. BLOCK DIAGRAM	4
4. CIRCUIT DIAGRAM	5
5. PC. BOARD	7
6. MAIN CIRCUIT EXPLANATIONS	9
7. ADJUSTMENT PROCEDURE	16
8. PARTS LIST	18

**KEIO ELECTRONIC LABORATORY CORPORATION
TOKYO/JAPAN**

1. SPECIFICATIONS

KEYBOARD	● C ~ C, 61 keys
DRAWBARS x 9	● 16', 5-1/3', 8', 4', 2-2/3', 2', 1-3/5', 1-1/3', 1'
PRESET-DRAWBARS	● I, II, III, Drawbars
PERCUSSION	● 4', 2-2/3', Percussion Volume, Percussion Decay
ROTARY EFFECT	● On, Fast
TONE CONTROLS	● Bass, Treble, Overdrive
TUNE	● Tune (± 50 CENTS)
VOLUME	● Power & Volume, key Click Volume
OUTPUTS	● Signal Outs x 2 (High/Low), Accessory Send
INPUTS	● Accessory Return, Rotary Effect (Slow/Fast)
DIMENSIONS	● 1149(W) x 137(H) x 315(D) mm
WEIGHT	● 10.5kg
ACCESSORIES	● Dust Cover, Connection Cord
POWER CONSUMPTION	● Voltage (Local Voltage, 50/60Hz), Wattage (5W)

2. STRUCTURAL DIAGRAM

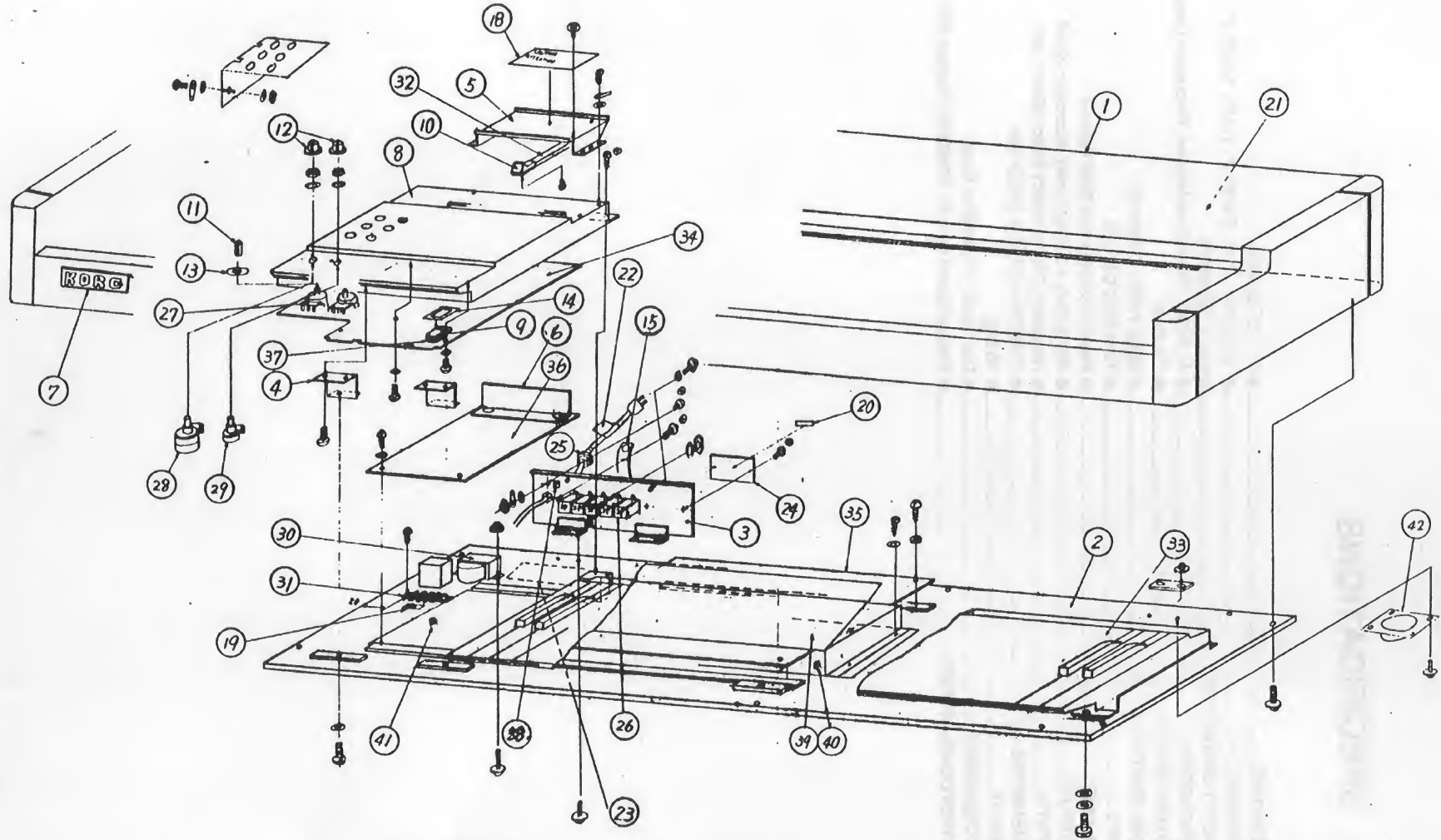

Item	Part Name	Remarks	Item	Part Name	Remarks	Item	Part Name	Remarks	Item	Part Name	Remarks
1.	Cabinet		11.	PS knob (small)		23.	Service caution seal		33.	Keyboard	
2.	Bottom		12.	Rotary knob		24.	Model number plate		34.	Control circuit board	
3.	Rear panel		13.	Lever SW, mask		25.	Strain release bushing		35.	Main circuit board	
4.	Control panel mounting		14.	Selector SW mask		26.	Phone Jack		36.	R.E. Circuit board	
5.	Draw bar holder		15.	Cord stopper		27.	Rotary variable resistors		37.	Selector SW	
6.	Radiation board		18.	Fuse caution seal		28.	Rotary variable resistors		38.	Earth (ground) seal	
7.	KORG Mark (Small)		19.	Fuse seal		29.	Rotary variable resistors		39.	Sealed cover	
8.	Control panel		20.	Serial number seal		30.	Power transformer		40.	Aluminum film	
9.	Selector SW knob		21.	KORG Mark seal		31.	Lug board		41.	Aluminum film	
10.	Draw bar knob		22.	Wiring caution (large)		32.	Draw bar		42.	Metal fitting of stand	

3. BLOCK DIAGRAM

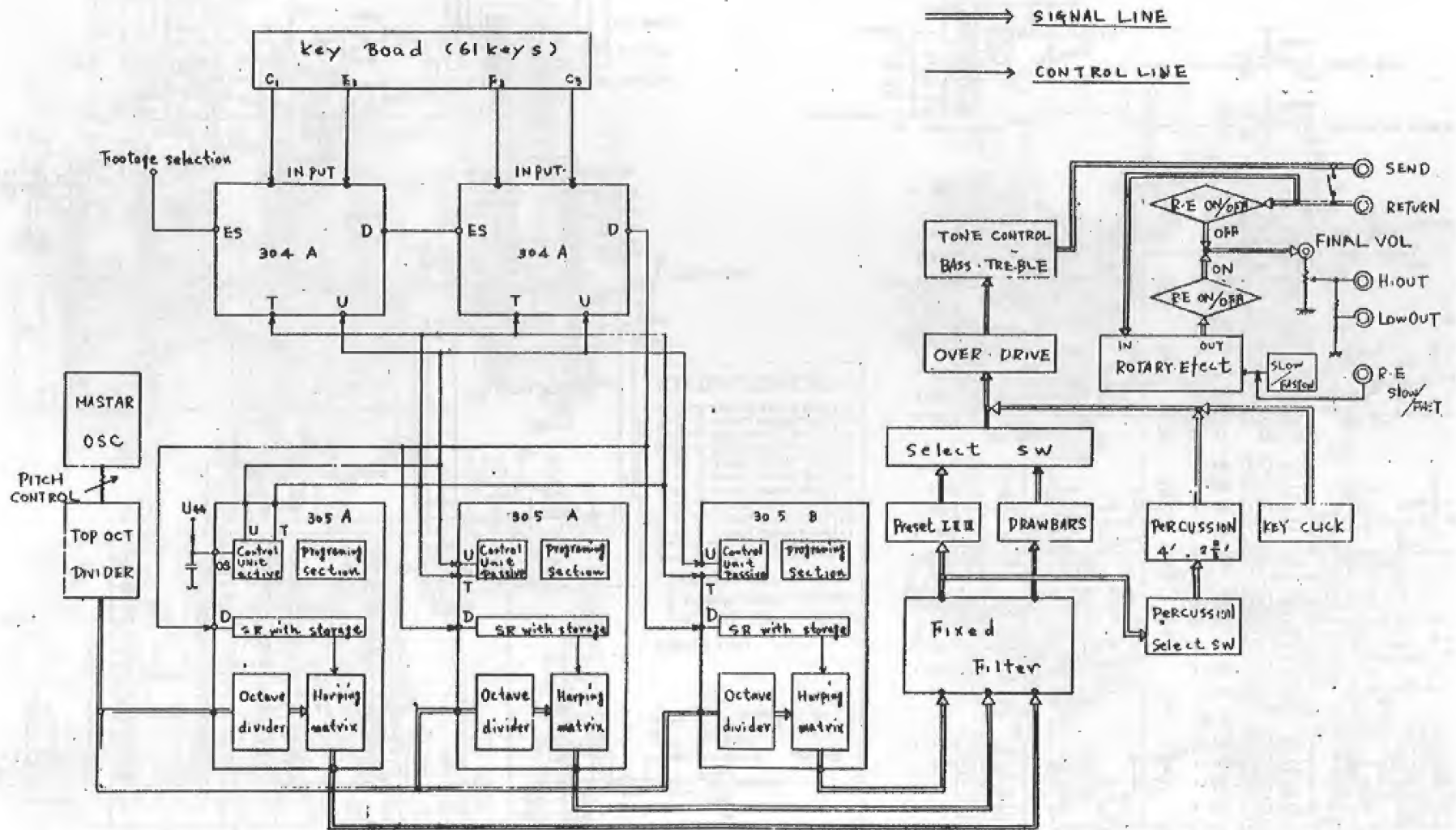

4. CIRCUIT DIAGRAM KLM-244

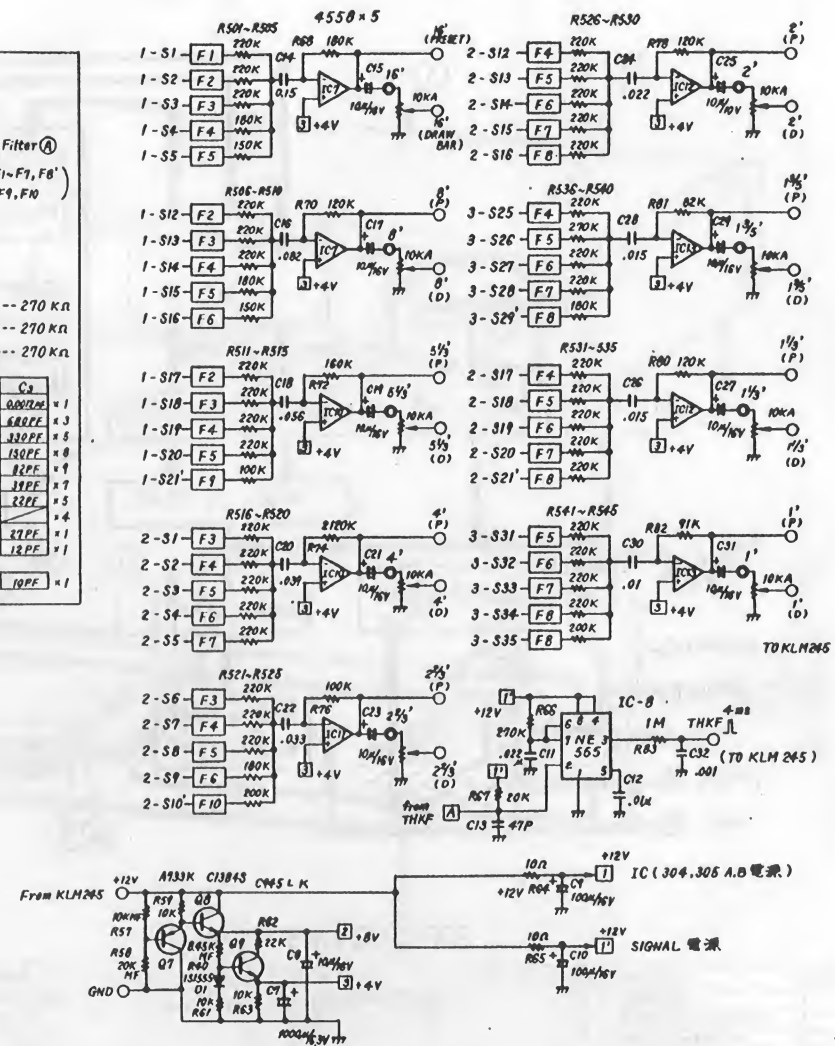
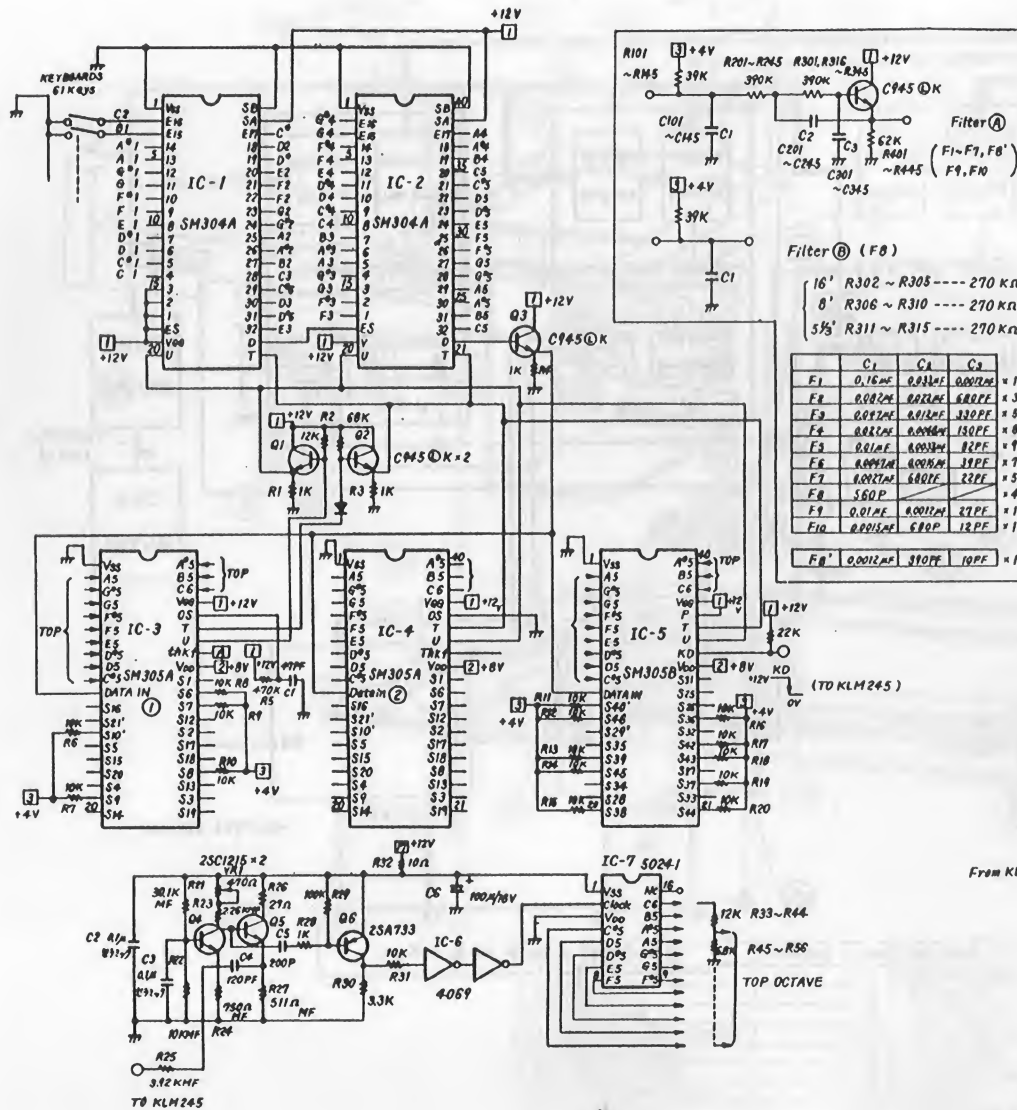

KLM-245

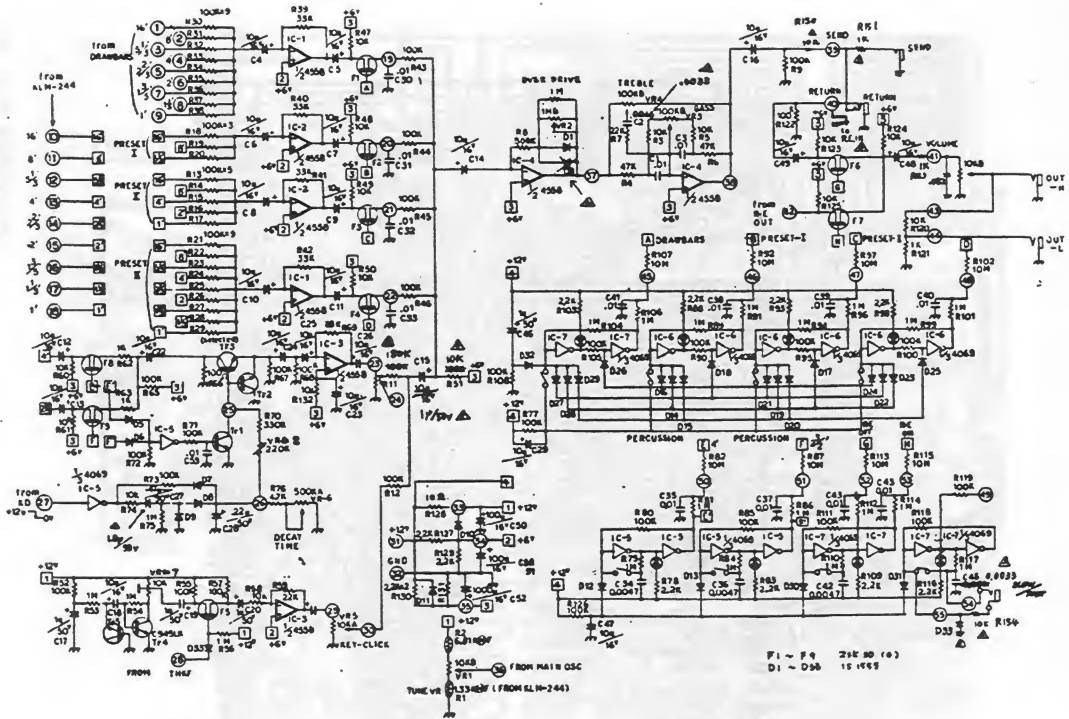

KLM-246

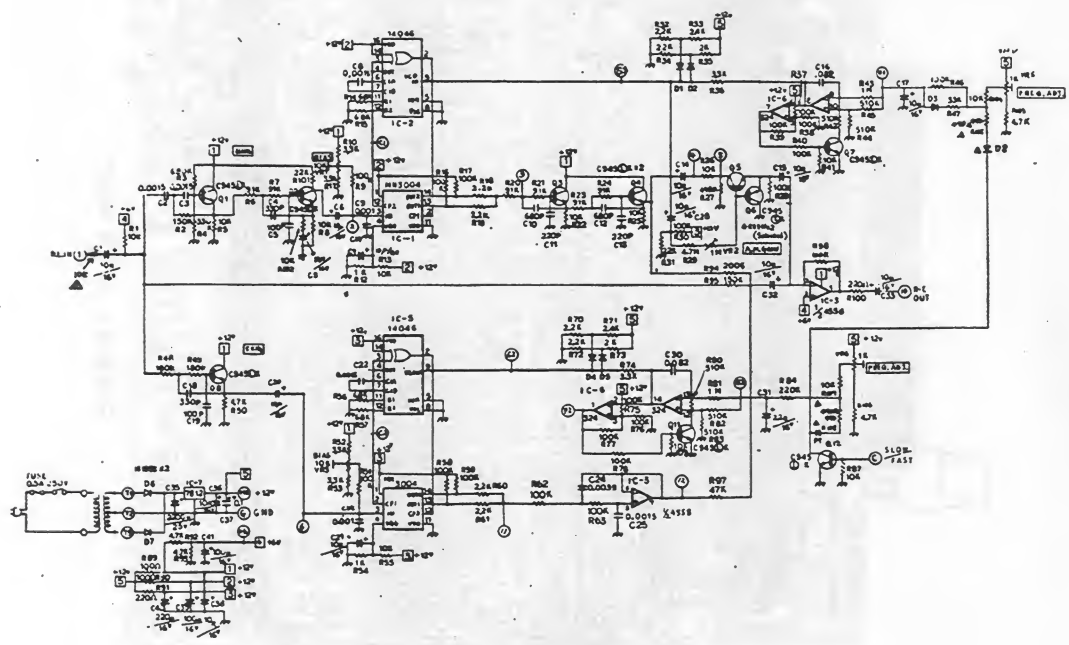

5. PC BOARD

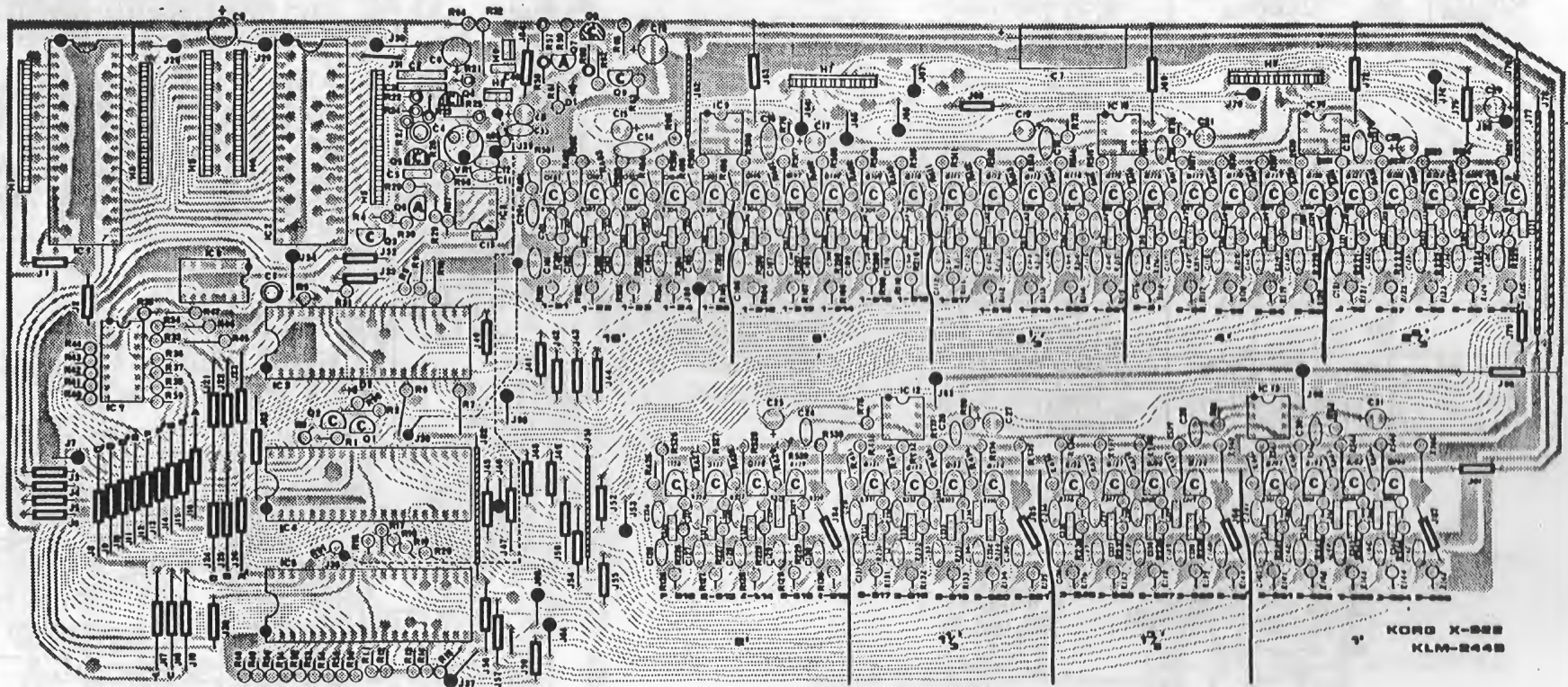

KORD X-222
KLM-2448

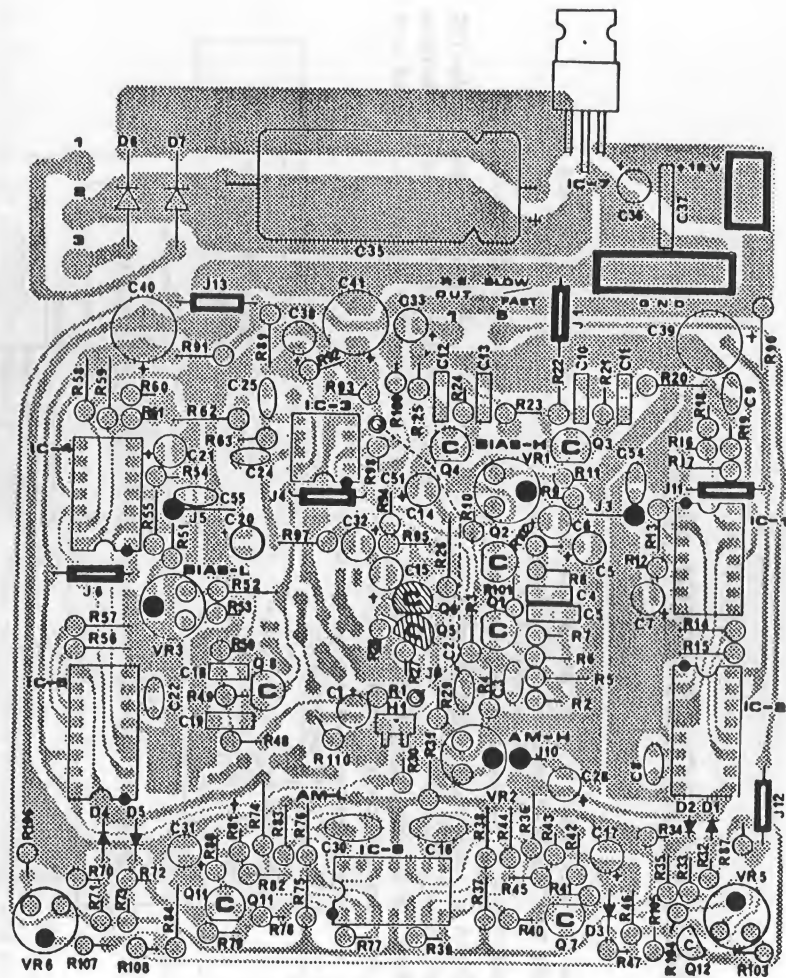
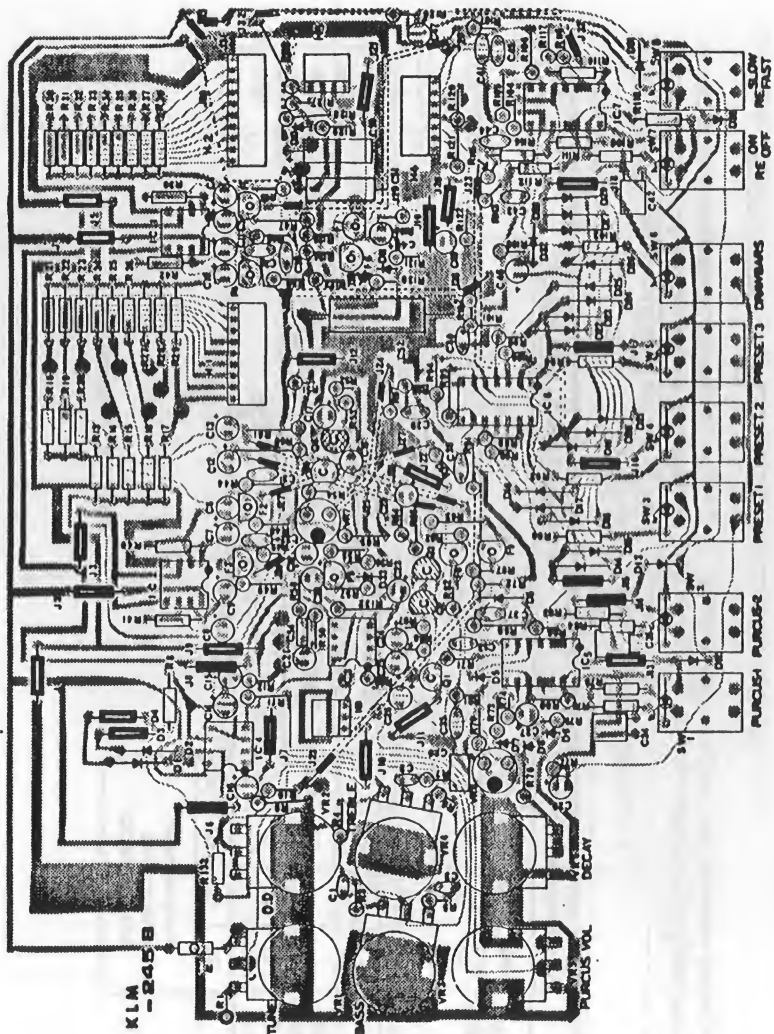

KORO KLM - 248C

6. MAIN CIRCUIT EXPLANATIONS

Because the tone circuit is of the programming type, it can be used in many different ways. However, here is only explained how the circuit is used in the CX-3.

1. Tone circuit

IC-SM304A is a data processing IC designed for electronic organ applications. Data from the 61 keys on the keyboard is converted from a parallel control signal into a series

control signal. After passing through the P/S (parallel-to-series) converter, the data is stored as D in the SR with storage of SM-305A and SM-305B.

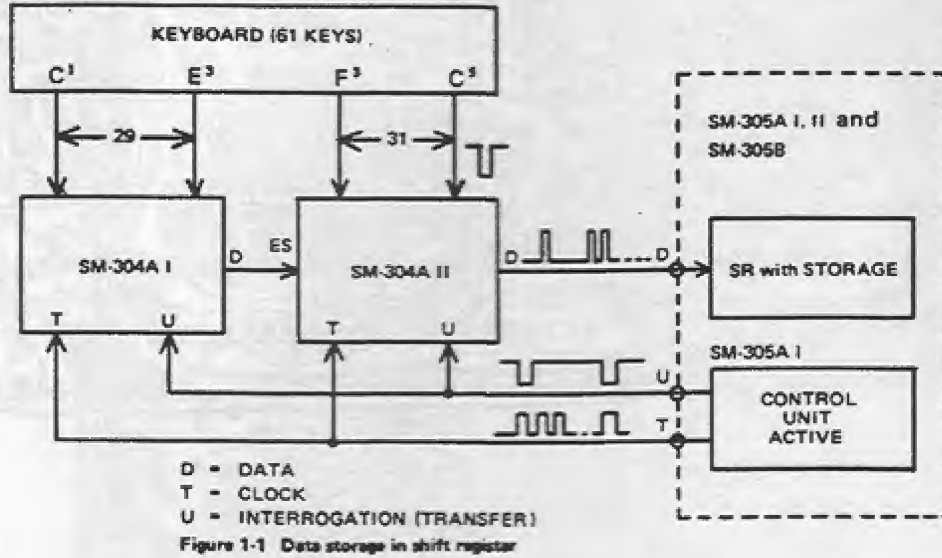

U = Simply speaking, the transfer pulse identifies the beginning of the series.

T = The clock pulse counts from 1 to 65 bits. 4 of those bits are for footage group programming and 61 bits are for keyboard programming. Refer to chart 1-2.

SM-305A	Programming bits				OS	Summing-out puts for programming					Footage group			
	PB1	PB2	PB3	PB4		S10'	S9	S6	S7	S8				
	H	H	H	H	RC or H	$\frac{VDD}{2}$					3			
	H	H	H	H	L						1			
SM-305B	Programming bits				P	Summing-outputs for programming								Footage group
	PB1	PB2	PB3	PB4		S40'	S46	S39	S45	S38	S36	S42	S43	
	H	H	H	H	H	$\frac{VDD}{2}$								4
	ES	E1	E2	E3										
Designation of programming bits for SM-304														

Chart 1-2 Programming

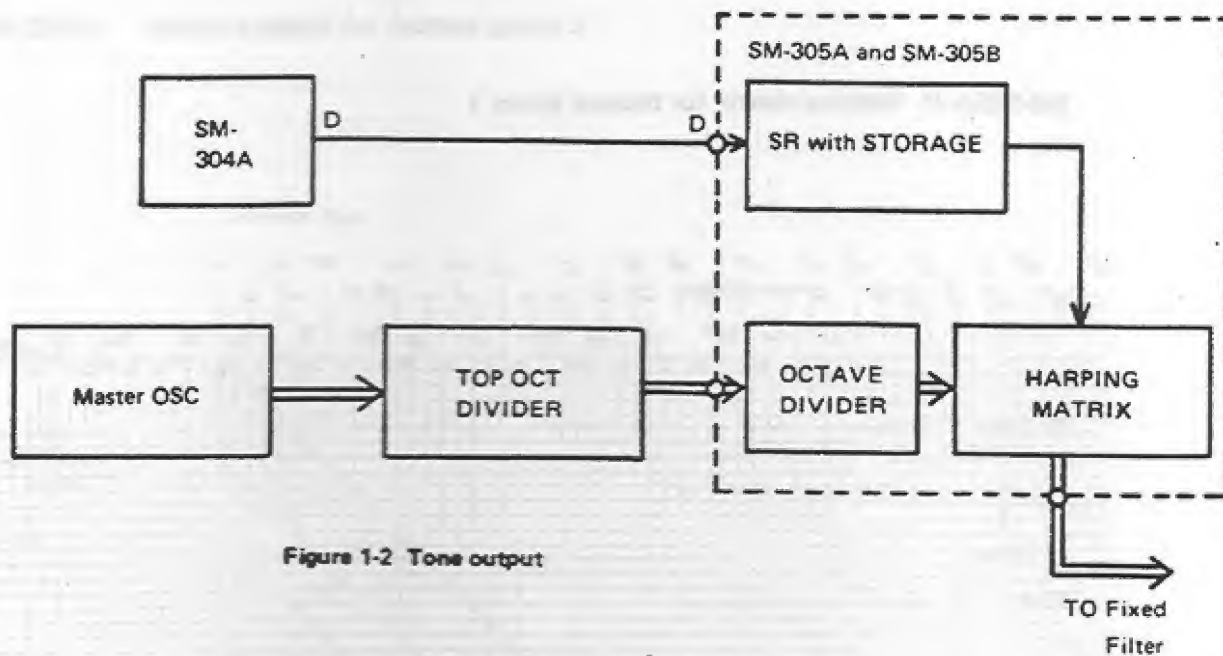

Figure 1-2 Tone output

IC SM-305 includes shift register, octave divider, and harping matrix functions.

The data that had been transferred to the shift register is now transferred to the harping matrix.

There the 12-tone octave divider and sound is produced in accordance with the data. Refer to figure 1-2.

Harping Matrix

SM-305A produces 3 footage groups.

Footage Group-1	4'	2-2/3'	2'	1-1/3'
Footage Group-2	8'	5-1/3'	4'	2-2/3'
Footage Group-3	16'	10-2/3'	8'	5-1/3'

SM-305B produces 2 footage groups.

Footage Group-4	1-3/5'	1'	2/3'	1/2'
Footage Group-5	4/5'	1/3'	1/4'	1/8'

Footage groups used in the CX-3 are as listed below.

SM-3054-I	Footage group-3	(But without 10-2/3')
SM-3054-II	Footage group-1	
SM-3058	Footage group-4	(But without 2/3' or 1/2')

(Refer to the Harping matrix – footage group chart)

In other words, the top octave divider produces 12 frequencies – C# (4434.96Hz) D, D# . . . B, C (8372Hz) etc. For example, to get 4' C, which is 4 octaves lower, the 4186Hz is divided by 32 to obtain 130.81Hz (C). This note centered around VDD/2 is sent to tone out and from there to each of the fixed filters.

SM-305A-II Harping matrix for footage group 1

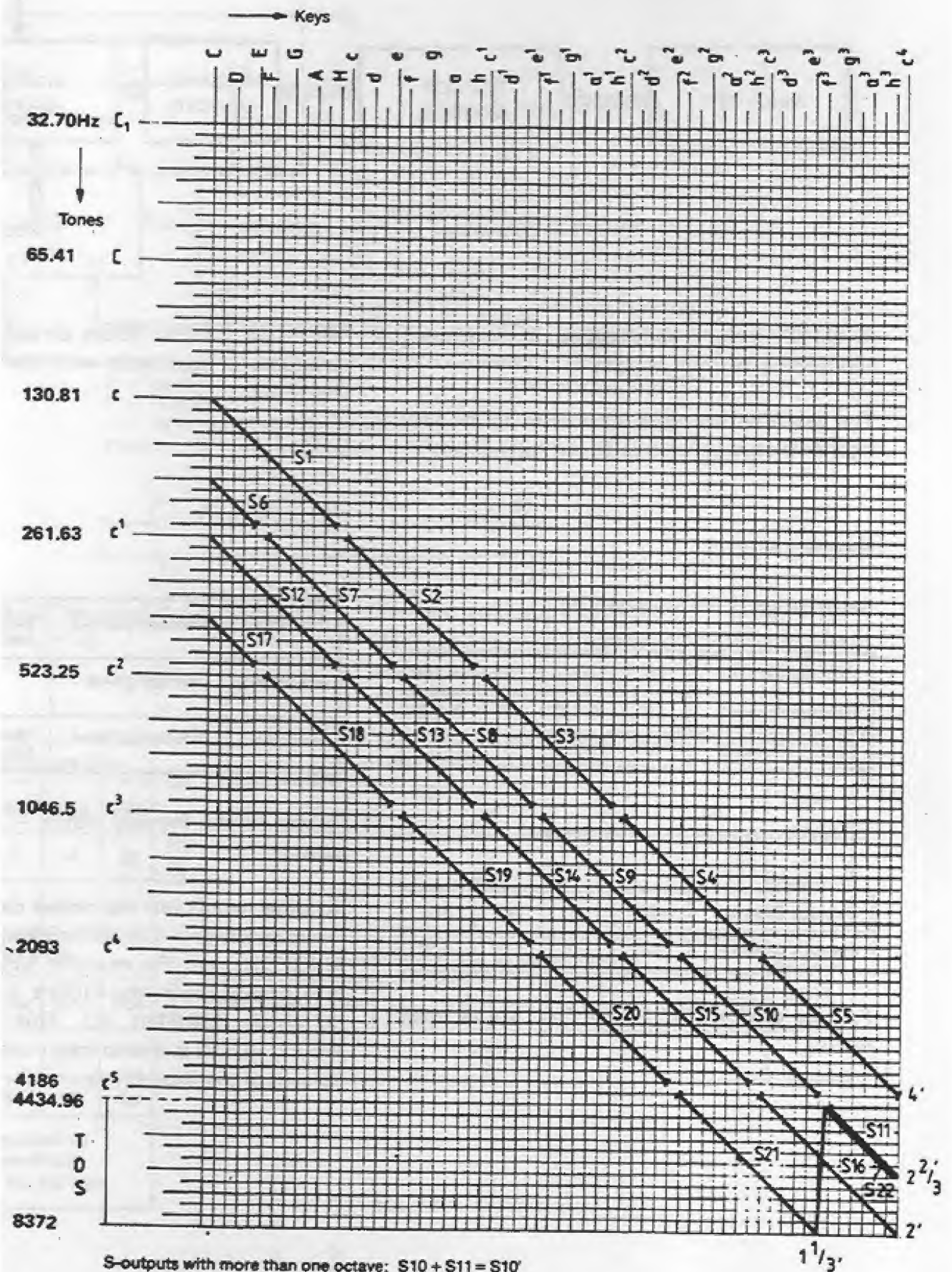

SA-305A-1 Harping matrix for footage group 3

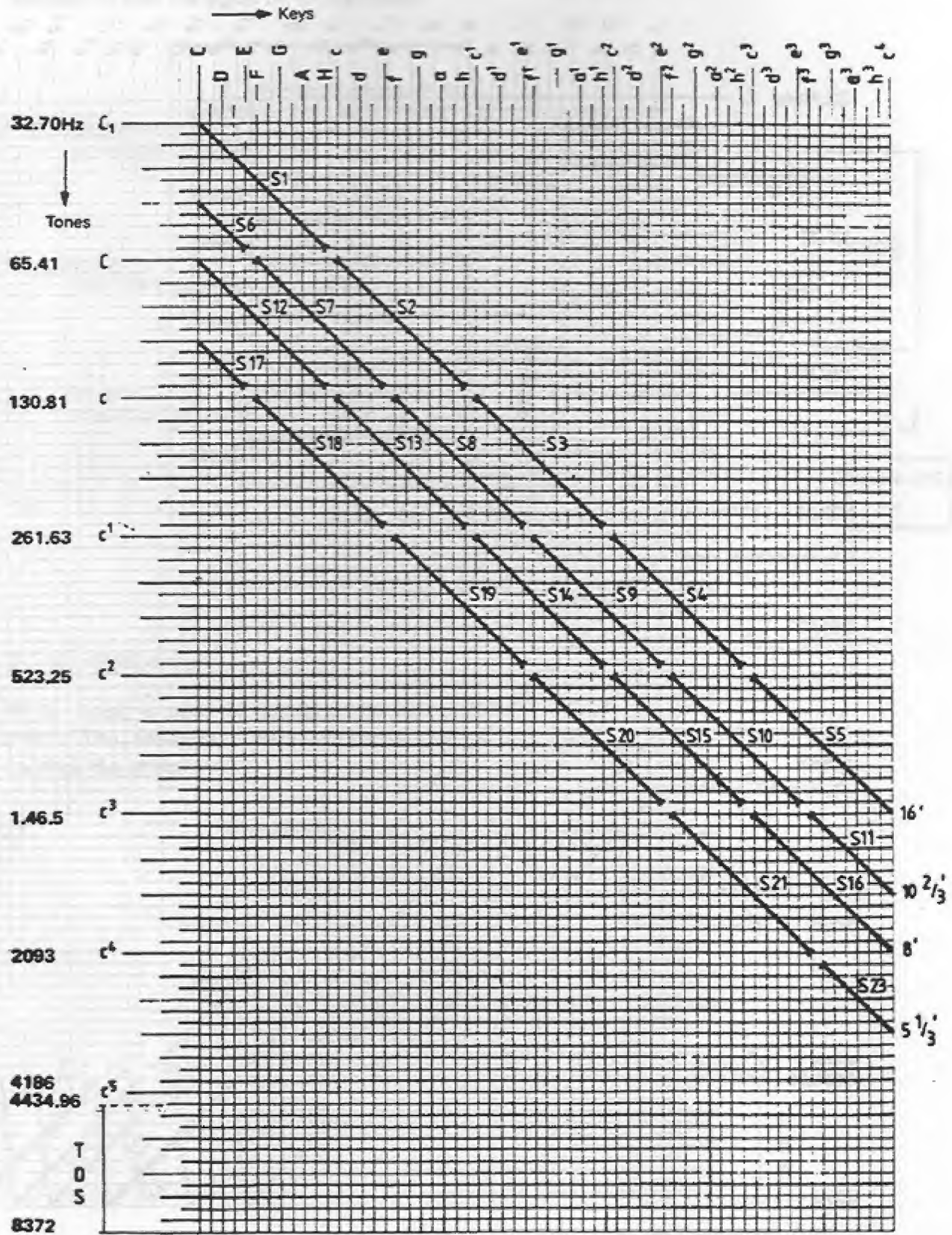

S-outputs with more than one octave: S10 + S11 = S10'
S21 + S23 = S21'

2. Filter circuitry

There are fixed filters for each tone; separate outputs are provided for presets and drawbars; the selector buttons determine which gate is operated to pass the signal on to the mixer.

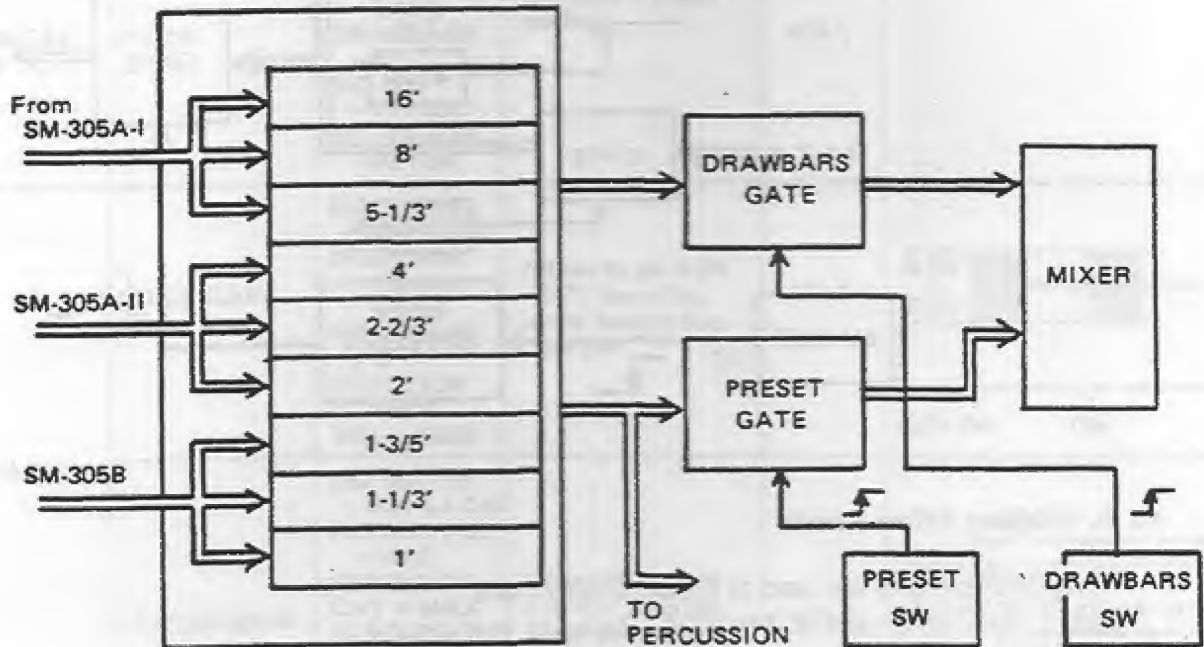
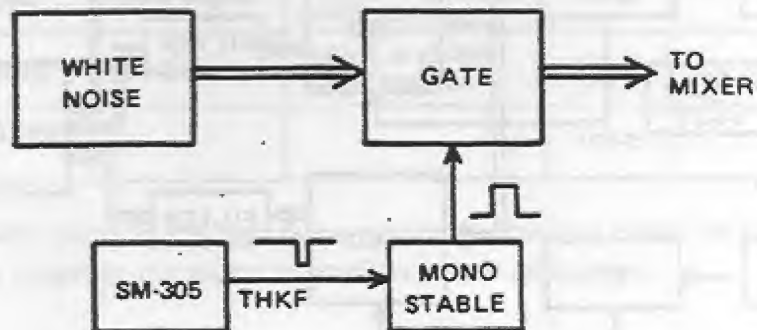

Figure 2-1 Filters.

3. Key-Click circuit

White noise is used to produce the key-click effect. The SM-305A THKF (multiple trigger) controls the effect.



4. Percussion circuit

The percussion circuit uses 4' and 2-2/3' signals. The envelope signal which controls the effect is produced with the SM-305B KD (key-down) single trigger.

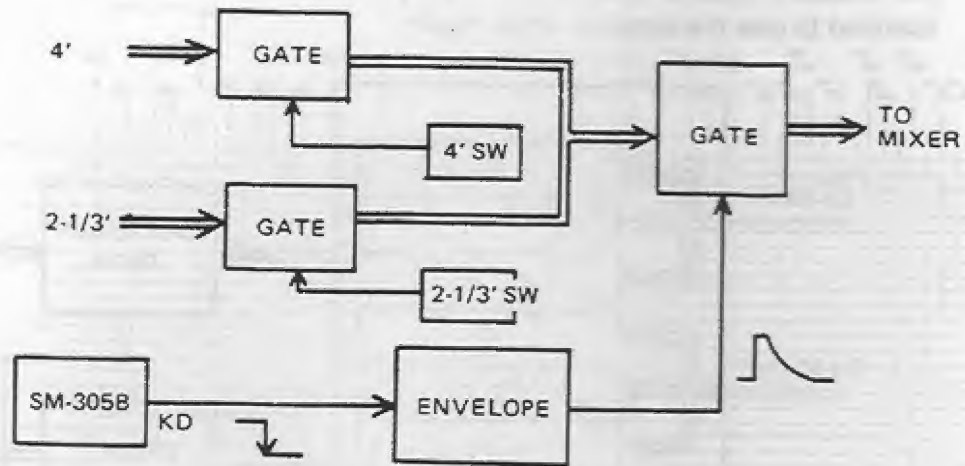

5. Rotary Effect circuit

Two BBD circuits are used to produce the rotary effect. The BBDs are IC-MN3004. Refer to the diagram

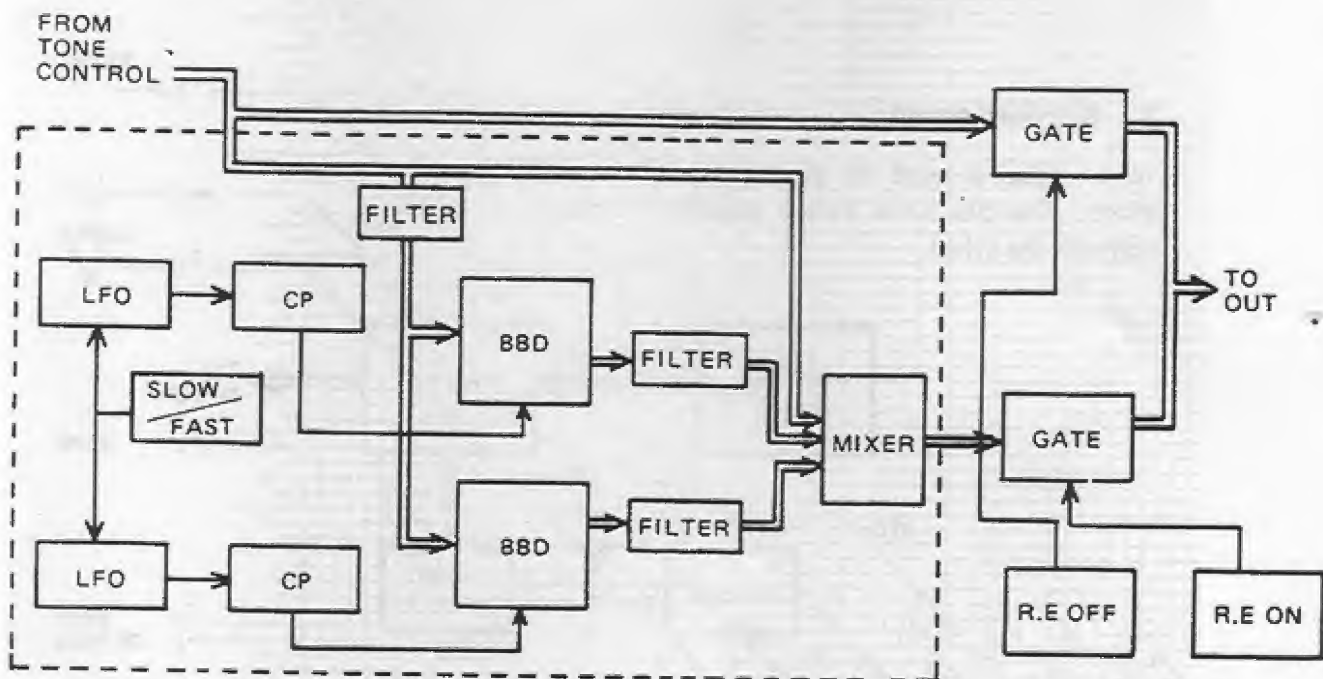

7. ADJUSTMENT PROCEDURE

Caution: Very precise adjustments have been made at the factory, so be careful not to change any setting other than that which is out of order.

Circuit Board No.	SECTION	SETTINGS	ADJUSTMENT	ADJUST Vr. No.	Oscilloscope
KLM-244	PITCH	TUNE - CENTER SELECTOR - DRAW- BARS DRAWBARS - 8' SIG OUT - WT10A WT-10A-S/M -METER	Play A and adjust to obtain a 0 cent reading.	VR-1	
KLM-245	NOISE GAIN	SIGOUT(Hi) - OSCILLO.S SELECTOR - DRAW- BARS DRAWBARS - 0 KEYCLICK - MAX VOL - MAX	Adjust to get 0.5V ~0.7V key click sound when a key is played.	VR-7	
	PERCUS GAIN	SIG OUT(Hi) - OSCILLO.S PERCUS VOL - MAX PERCUS DE- CAY - MAX PERCUSSION - 4' SELECTOR - DRAW- BARS DRAWBARS - 4'	Adjust so there is a 7:1~5:1 ratio between percussion 4' and drawbars 4'.	VR-8	
KLM-246	LFO (LOW)	ROTARY EFFE - FAST IC6-1 - f.counter	Adjust to obtain 145msec reading.	VR-6	
	LFO (HIGH)	IC6-7 - f.counter	Adjust to obtain 130msec reading.	VR-5	
	BIAS (LOW)	IC4-3-Digital	Adjust to obtain 6.00V reading.	VR-3	
	BIAS (HIGH)	IC1-3-Digital	Adjust to obtain 6.00V reading.	VR-1	
	AM-H		*	VR-2	

* The AM-H adjustment controls the high range volume fluctuation when the rotating speaker effect is turned on. Listen to the sound to confirm proper adjustment.

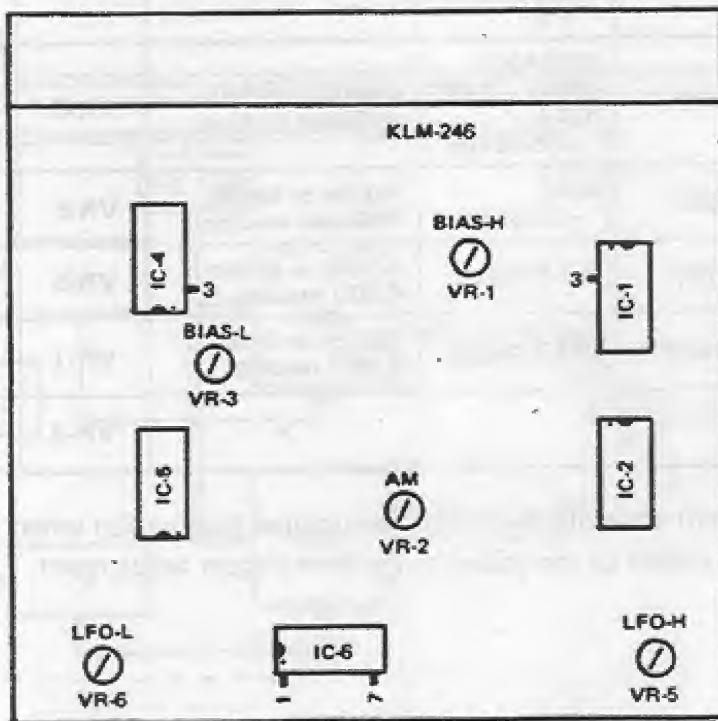
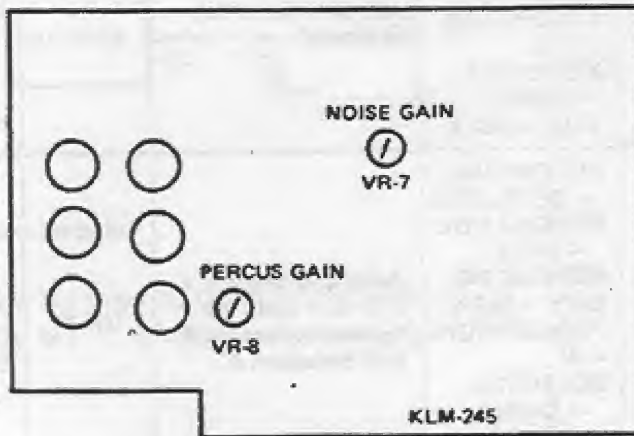
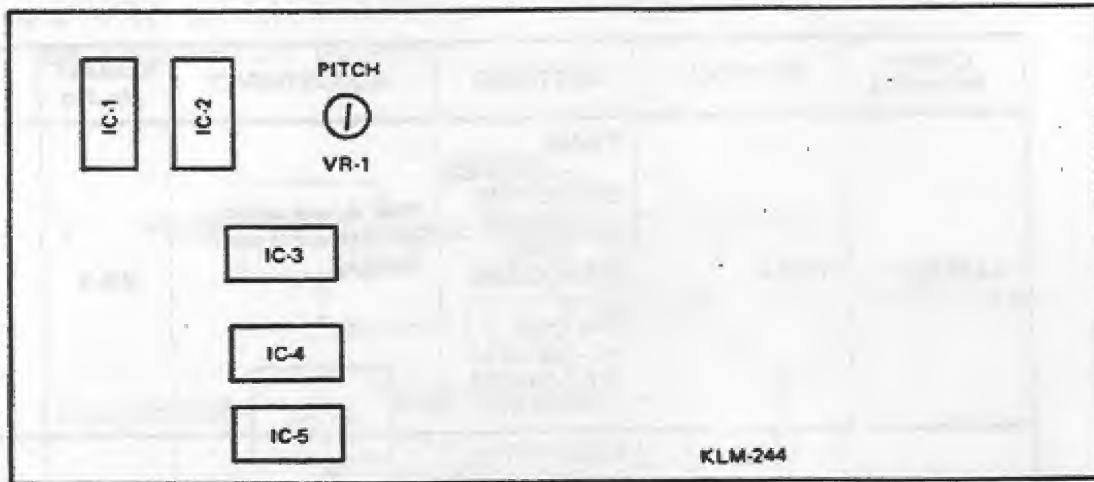

Trimmer positions (reference chart)



8. PARTS LIST

(Refer to structural diagram for parts list.)

PARTS NAME	SPECIFICATIONS	Q'TY	PARTS NAME	SPECIFICATIONS	Q'TY
CARBON RESISTORS (Not Listed)			CERAMIC CAPACITORS		
SOLID RESISTORS			561	(560 pF)	4
¼W	10MrJ	8	ECK-FIE104ZFZ	(0.1 µF)	3
METAL FILM RESISTORS			ELECTROLYTIC CAPACITORS		
¼W	1.33 KµF	1	0.22µ	/ 50V	1
	6.81	1	0.47		
	511	1	10	/ 16	24
	750	1	100		5
	3.32	1	1000	/ 6.3V	1
	3.92	1	220	/ 16	1
	8.45	1	1000	/ 6.3	1
	10	2	100	/ 16	2
	20	1	2200	/ 25	1
	30.1	1	22	/ 16	1
	2.32	0	1	/ 50	7
	2.26	1	10	/ 16	22
MYLAR CAPACITORS			TRANSISTORS		
50V	0.001µF k	3	2SC945 LK		55
	0.0012	3	2SC945		4
	0.0015	13	2SC1215T		2
	0.0022		2SC644R		1
	0.0027	5	2SC13849		1
	0.0033	11	2SA733AK		2
	0.0039	1	FET		
	0.0047	10	2SK30		9
	0.0068	8	DIODES		
	0.01	27	1S1555		40
	0.012	5	1S1885		2
	0.022	13	IC		
	0.033	2	SM-304A		2
	0.047	5	SM-305A		2
	0.068		SM-305B		1
	0.082	7	NE-555		1
	0.16	1	S-50241		1
	0.056	1	MC-14069		4
	0.15	1	4458		10
	0.015	2	MC-14046		2
	0.039	1	MN-3004		2
STYROL CAPACITORS			µPC 324		1
47 pF G (5%)		1	14312 (7812)		1
120 (1%)		1	SEMI-FIXED RESISTORS		
CERAMIC CAPACITORS			470ΩB H1051A		1
ECK-D1H100 Dc (10 pF)		1	150		3
120 K ₂ (12 pF)		1	10KB		3
220 (22 pF)		5	220		1
270 (27 pF)		1	1MB		1
390 (39 pF)		7	100KB		
820 (82 pF)		9	1KB		2
101 (100 pF)		3	KEYBOARD		
151 (150 pF)		8	ESK307V (61 key)		1
221 (220 pF)		3	FUSE		
231 (330 pF)		7	250V 0.5A		1
391 (390 pF)		1	LUG BOARD		
681 (680 pF)		11	L-1205-6P		1
47 (47 pF)		1			

PARTS NAME	SPECIFICATIONS	Q'TY
CONNECTORS		
CX3-1	KO-131	1
	132	1
	121	1
	122	1
	123	1
	101	1
	91	1
	71	1
	41	1
	21	1
	22	1
	92	1
	32	1
	TRC-1	1
	100	1
TOP ENTRY		
	13P (B13P-SHF-1)	2
	12 (B12P-SHF-1)	3
	9 (B9B-SHF-1)	2
	3 (B3P-SHF-1)	1
	2P (B2P-SHF-1)	2
BOTTOM ENTRY		
	10P (BE10P-SHF-1)	1
	9 (BE9P-SHF-1)	1
	7 (BE7P-SHF-1)	1
	4 (BE4P-SHF-1)	1
	3 (BE3P-SHF-1)	1
PRINTED CIRCUIT BOARD		
	(KLM244)	1
	(KLM245)	1
	(KLM246)	1
BUSHING		
	SR-6W-1	3
POWER TRANSFORMER		
	JA-221-12	1
	JB-221-12	1
BUSHING		
	4K-4	3
	5P-4	3

PARTS NAME	PANEL INSTRUCTION	STANDARD
POTENTIOMETERS		
VOLUME		EVC-BO5P18B14
KEY CLICK		EVH-8MA803A14
TUNE		EVH-LOAS20B14
OVER DRIVE		EVH-LOAS20B16
BASS		EVH-LOAS20B15
TREBLE		EVH-LOAS20B15
PERCUS DECAY		EVH-LOAS20A55
PERCUS VOL		EVH-LOAS20A14
SLIDE VOLUME		
DRAWBAR x 9		S401XKA10KC
SELECT SWITCH		
SELECT x 8		KHC11901 with LED
ROTARY KNOB		
	Rotary knob (Large) 18φ	
	Rotary knob (Small) for PS	
DRAWBAR KNOB		
Drawbar knob 5-1/3" ~	} No.1	2
Drawbar knob 2-2/3" ~		3
Drawbar knob 1-3/5" ~ Brown		4
Drawbar knob 1-1/3" ~		5
Drawbar knob 16" ~		6
Drawbar knob 8" ~	} Ivory	7
Drawbar knob 4" ~		8
Drawbar knob 2" ~		9
Drawbar knob 1"		
	Select knob (gray)	
	Select knob (Brown)	
PHONE JACK		
RETURN		0929
OTHERS x 4		0983